



Graastein 2

LK 8624



Graastein 2

LK 8624

General information

Name	Graastein 2
Builder	Krasnojarsk, Russland
Flag	Norway
Port of Registry	Trondheim
Call sign	LK 8624
Class society	Not in class. Only insurance survey
Year build	1992
Manager	Johs. J. Syltern AS

Equipment

Aux equipment	Iveco, type 8065, 126 HK w/electrical equipment, cooler etc. Hydraulic tank Pumps, Rexroth A10VO71, Sauer JV 38 SA 40 RX
Anchor	4 anchors
Deck winches	4 x 7,0 tonn hydraulic winches with 110 meter x 22 mm wire
Mooring lines	4 pcs 48 mm x 55 meter
Navigation lights	Supplied by tug
Power supply	Generator 15 kw / 400 v / 50 Hz
RoRo ramps	One ramp in the front with two ad- justable drivingramps of 1,8 meter x 10 meter

Dimensions/Capacities

Length overall	85,7 meter
Breadth, moulded	16,48 meter
Depth, moulded	3,3 meter
Draught, fully loaded	2,26 meter
Gross tonnage	1413
Net tonnage	423
Deck area	67,2 x 13,9 meter
Cargo capacity	2000 tonn
Deck strength	10 t/m ²
Flooring	Steel, reinforced on top with a layer of

Ballast system

Tanks	Totally 18 dry tanks, without ballast systems
Towing & Mooring Equipment	Supplied from tug
Smithbrakes	No
Towing bridle	Supplied from tug
Emergency towing	Supplied from tug
Bollards	6 on each side of barge

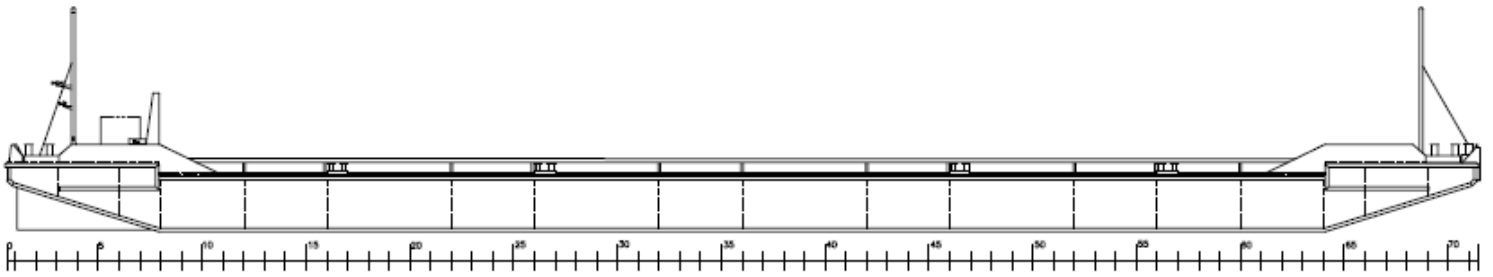

PROFIL

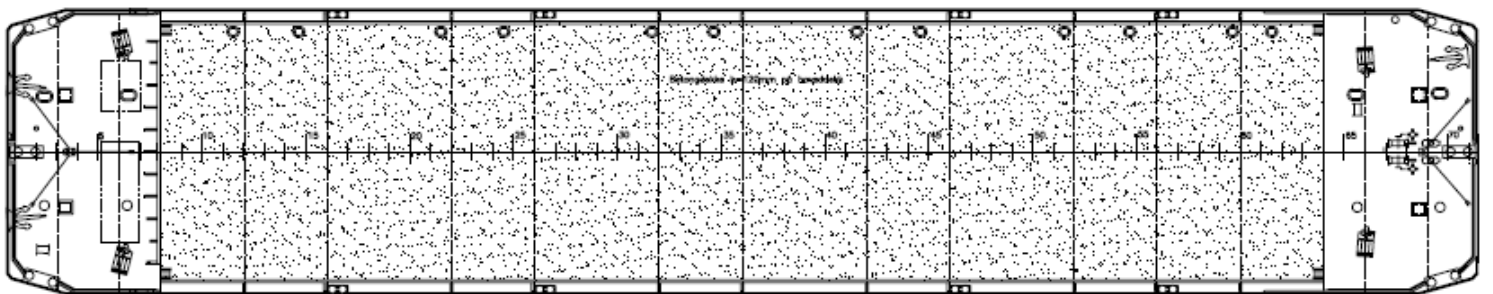

HOVEDDEKK

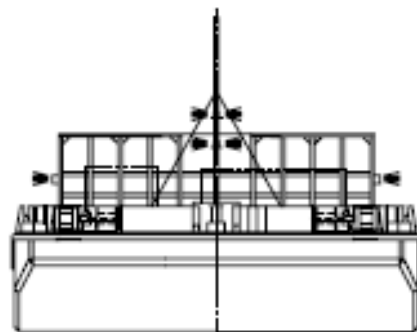

AKTERSKIP
sett forover

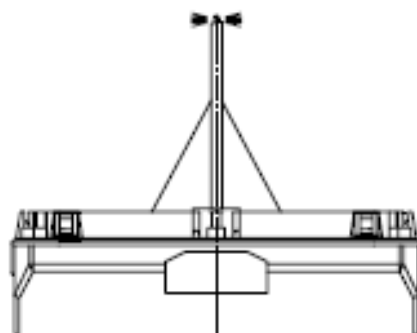

FORSKIP
sett akterover



Johs J. Syltern AS

Vassneset 10 • 7170 Åfjord

Tlf: 99 28 78 06

lekter@syltern.no

www.syltern.no